

Honeywell

THE Y343B IGNITION PACKAGE PROVIDES DIRECT SPARK IGNITION (DSI) FOR GAS HEATING SYSTEMS. THE PACKAGE INCLUDES THE S87D ELECTRONIC MODULE, Q354A FLAME SENSOR, Q347A SPARK IGNITER-SENSOR AND 392286-1 IGNITION CABLE.

DEPENDABLE BURNER IGNITION

Spark generated by electronic module and internal step-up transformer.

SOLID STATE DESIGN

- Compact, solid state components provide accurate, long-lasting performance.
- No mechanical friction or wear.

MAXIMUM OPERATING SAFETY

- Proves presence of flame on burner ignition, then protects against burner flame-out and interruption of electric power or gas supply during run cycle.
- Open or short circuit in any electronic component results in safety shutdown.

USES FLAME RECTIFICATION PRINCIPLE

- Any false flame signal, including electrical short or ground, results in safety shutdown.
- Ignition is started, main burner is ignited, burner flame is proved and continuously monitored during main burner-on period. Ignition spark is discontinued when flame is proved.

CONVENIENT REMOTE RESTART PROCEDURE

- After safety shutdown, equipment must be manually reset from remote thermostat or temperature controller.
- System automatically locks out after trial-for-ignition. If malfunction exists, correction must be made before system is manually reset.

LOW VOLTAGE CONTROL CIRCUIT

- Permits use of 24 V thermostat for optimum temperature control.
- Reduced wiring costs — both on appliance and on job.

GAS VALVE CONTROL

- S87D internal relay switches the gas valve on and off.
- System can be used with a 2-stage gas valve, if desired.

ALARM CONTROL

- Optional alarm circuit provides 24 Vac for an automatic visual or audible signal if any part of system malfunctions and causes a lockout.

L.H.
1-83•

Form Number 68-0014
©Honeywell Inc. 1983

DIRECT SPARK GAS BURNER IGNITION PACKAGE

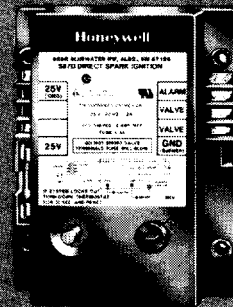

S87D



392286-1
IGNITION CABLE



Q354A

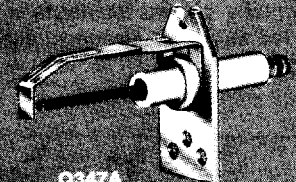

Q347A

Y343B1002

SPECIFICATIONS

The Y343B1002 Direct Spark Gas Burner Ignition Package includes the S87D Electronic Module, Q347A Spark Igniter-Sensor, Q354A Flame Sensor and 392286-1 Ignition Cable Assembly.

Other controls needed to complete the heating system include a 24 V, DSI gas valve; 24 V thermostat; 24 V transformer and high temperature limit controller.

S87D CONTROL MODULE

The S87D contains the electronic components of the system and also serves as a central wiring panel for the external controls. Powered by a 24 V transformer and controlled by a thermostat, it performs the following functions.

1. Checks for a false flame condition (short to ground). Module will lock out if false flame condition is present.
2. Generates a potential of 15,000 V (open circuit) at the spark-igniter stud for direct ignition of the main burner.
3. Operates gas valve (internal relay controls independent gas valve circuit).
4. Senses the presence of main burner flame and discontinues ignition spark. If the burner fails to ignite within the trial-for-ignition period, safety lockout occurs.
5. If there is a loss of power, the system will shut down safely. Start-up is initiated when power is restored.
6. If there is a loss of main burner flame, the timed trial-for-ignition is repeated. Safety shutdown occurs if flame is not reestablished within the trial-for-ignition period.
7. Normally closed contacts in internal relay may be used for an alarm circuit to signal safety shutdown of system.

ELECTRICAL RATINGS:

Voltage and Frequency—24 Vac, 60 Hz.

Current Rating—0.2 A plus gas valve current draw.

SAFETY LOCKOUT TIMING: 11 seconds.

FLAME FAILURE REIGNITION TIME: 0.8 seconds maximum.

FLAME CURRENT SIGNAL REQUIRED: 1.5 μ A dc minimum.

SPARK GENERATOR VOLTAGE: 15,000 V open circuit.

MOUNTING: Mounts in any position. See Fig. 1.

DIMENSIONS: See Fig. 1.

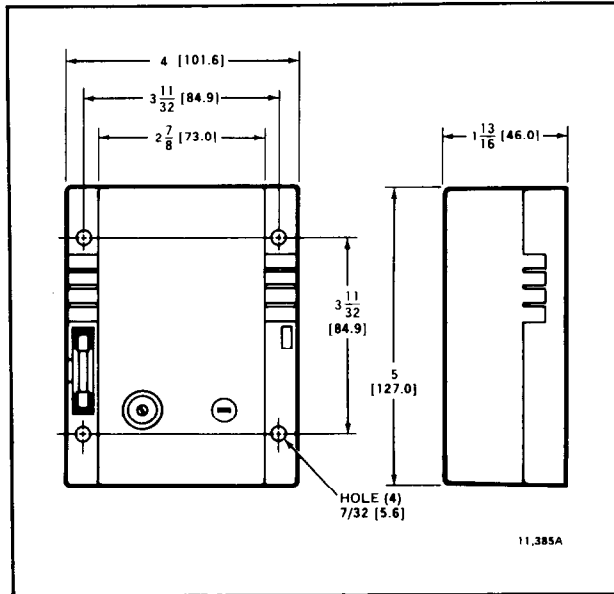

FIG. 1—DIMENSIONS FOR S87 IN in. [mm IN BRACKETS].

(continued on page 3)

ORDERING INFORMATION

WHEN PURCHASING REPLACEMENT AND MODERNIZATION PRODUCTS FROM YOUR TRADELINE WHOLESALE OR YOUR DISTRIBUTOR, REFER TO THE TRADELINE CATALOG OR PRICE SHEETS FOR COMPLETE ORDERING NUMBER, OR SPECIFY—

- | | |
|---|--|
| <ol style="list-style-type: none"> 1. Order number Y343B1002. 2. Safety lockout timing (11 seconds). 3. DSI system controls, as required. <ol style="list-style-type: none"> a. 24 V, 60 Hz transformer. b. Low voltage thermostat or temperature controller. | <ol style="list-style-type: none"> c. Combination gas control (for DSI application). d. High limit temperature controller and auxiliary safety controls. e. Alarm signal (if required). |
|---|--|

IF YOU HAVE ADDITIONAL QUESTIONS, NEED FURTHER INFORMATION, OR WOULD LIKE TO COMMENT ON OUR PRODUCTS OR SERVICES, PLEASE WRITE OR PHONE:

1. YOUR LOCAL HONEYWELL RESIDENTIAL SALES OFFICE (CHECK WHITE PAGES OF YOUR PHONE DIRECTORY).
2. RESIDENTIAL DIVISION CUSTOMER SERVICE
HONEYWELL INC., 1885 DOUGLAS DRIVE NORTH
MINNEAPOLIS, MINNESOTA 55422 (612)542-7500

(IN CANADA—HONEYWELL LIMITED/HONEYWELL LIMITEE, 740 ELLESMERE ROAD, SCARBOROUGH, ONTARIO M1P 2V9). INTERNATIONAL SALES AND SERVICE OFFICES IN ALL PRINCIPAL CITIES OF THE WORLD.

AMBIENT TEMPERATURE RATING: Minus 40 F to plus 175 F [minus 40 C to plus 79 C].
WIRING CONNECTIONS: 1/4 in. [6.4 mm] male quick-connect terminals, for all except ALARM terminal. ALARM terminal, 1/4 in. [6.4 mm] female quick-connect. 1/4 in. [6.4 mm] diameter stud base for ignition cable.
REPLACEMENT PARTS: 3 A fuse.

Q347A SPARK IGNITER-SENSOR

The Q347A, powered by the S87D Electronic Module, produces a spark for direct ignition of the main burner. The Q347A consists of an inner electrode (insulated rod) and an outer electrode (rigid, formed strap bent at end to extend over tip of inner rod). Tip of electrodes extend into path of main burner gas; arcing across spark gap ignites gas.

SPARK GAP: 5/32 in. [4 mm].
LENGTH OF ELECTRODE ASSEMBLY (mounting surface to tip): 2-3/8 in. [60.3 mm].
ELECTRODE MATERIAL: Kanthal.
MAXIMUM TEMPERATURE RATINGS: 1800 F [982 C] at tip of electrode assembly, 1250 F [677 C] at ceramic insulator.
WIRING CONNECTION: 1/4 in. [6.4 mm] diameter base stud for ignition cable.
MOUNTING: Bracket, see Fig. 2.
DIMENSIONS: See Fig. 2.

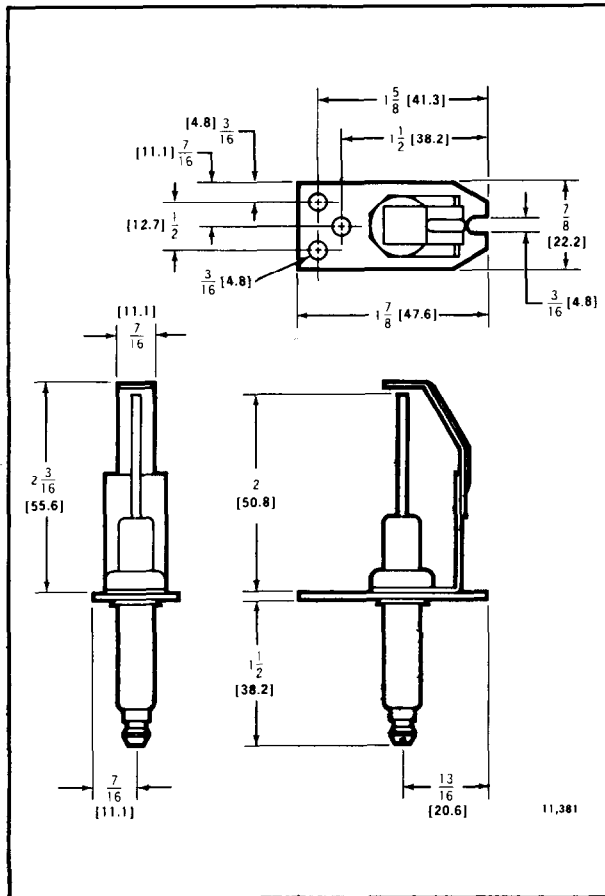

FIG. 2—INSTALLATION DIMENSIONS IN in. [mm IN BRACKETS] OF Q347A.

Q354A FLAME SENSOR

The Q354A consists of a flame rod supported in a ceramic insulator with mounting bracket. Positioned so that the end of the flame rod is immersed in the main burner flame, and with the burner head serving as the ground area, it operates on the flame rectification principle. In the presence of main burner flame, a direct current is established to prove burner ignition and to continuously monitor the flame during the burner-on period.

MAXIMUM TEMPERATURE RATING: 2200 F [1204 C] at tip of rod, 1250 F [677 C] at ceramic insulator.
WIRING CONNECTION: 1/4 in. [6.4 mm] male quick-connect terminal.
FLAME ROD MATERIAL: Kanthal.
MOUNTING: Bracket, see Fig. 3.
DIMENSIONS: See Fig. 3.

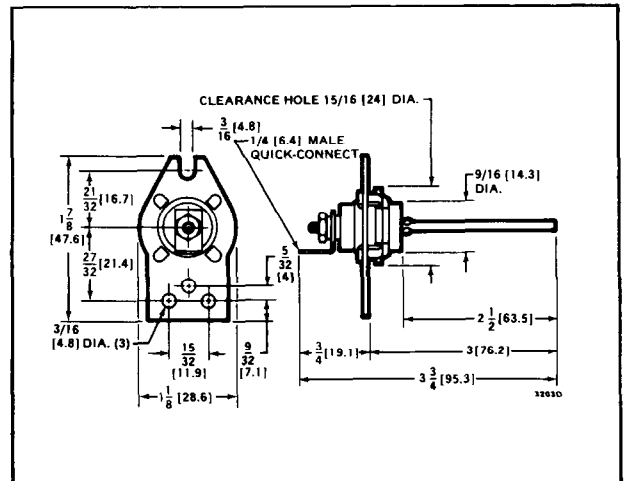

FIG. 3—DIMENSIONS IN in. [mm IN BRACKETS] OF Q354A.

392286-1 IGNITION CABLE

This cable is used to connect the Q347A Spark Igniter-Sensor to the S87 Electronic Module.
CABLE: No. 16 gauge high tension, 485 F [251 C] heated, oil resistant.
LENGTH: 30 in. [762 mm].
CONNECTORS (2): 1/4 in. [6.4 mm] diameter spring clip type with insulating boot. Two straight boots.

GAS CONTROLS

Combination gas controls are directly controlled by the internal relay in the S87D. Maximum electrical rating for DSI gas valve control is 2.0 A. See individual publication for complete specifications and installation instructions on the following recommended gas controls.

TABLE 1—GAS CONTROLS.

MODEL NO.	TYPE OF PRESSURE REGULATOR	CAPACITY RANGE OF STANDARD MODEL		PUBLICATION FORM NUMBER
		cfh	m ³ /hr	
V845A	Standard	110 to 335	3.1 to 9.5	60-2315
VR8450A	Standard	110 to 290	3.1 to 7.8	68-0016
V845C	Step-open	110 to 335	3.1 to 9.5	60-2315
VR8450C	Step-open	110 to 290	3.1 to 7.8	68-0016
VR8540A	Two-stage	110 to 290	3.1 to 7.8	68-0021
VR8590A	Negative	37 to 400	1.0 to 11.3	68-0017
VR8600A	Negative	37 to 400	1.0 to 11.3	68-0017

AUXILIARY CONTROLS

REQUIRED FOR BASIC DSI SYSTEM

1. **TRANSFORMER.** Select transformer with adequate VA. S87D requires a 24 Vac transformer. For common system transformers, capacity must be adequate for S87D, temperature controller, gas control and any other device powered by the transformer (see Table 2).

2. **LOW VOLTAGE TEMPERATURE CONTROLLER.** Select a 24 Vac thermostat for single-stage or two-stage burner control (depending on heating system).

DETERMINED BY PARTICULAR APPLICATION

Refer to separate publications for information on the controls utilized by the appliance manufacturer. These

controls are:

1. High limit temperature controller and other safety controls as required.
2. Gas valve. Refer to Table 1 above.
3. Alarm signal as desired for the circuit under control of the S87D.

CAUTION

1. When using a common transformer to power both S87D and gas control circuit, use a good quality transformer of adequate VA. If transformer VA is inadequate, the S87D internal relay may chatter.
2. When two or more transformers are used, they must be properly phased and grounded.

INSTALLATION

WHEN INSTALLING THIS IGNITION PACKAGE . . .

1. Read these instructions carefully. Failure to follow them could damage the product or cause a hazardous condition.
2. Check the ratings given in the instructions and on the product to make sure it is suitable for your application.
3. The installer must be a trained, experienced service technician.
4. After installation is complete, check out system operation.

CAUTION

1. Disconnect power supply before wiring to prevent electrical shock or equipment damage.
2. If a new gas control is to be installed, turn off gas supply before starting installation. Be sure to conduct a Gas Leak Test after the gas control is installed (follow manufacturer's instructions).

IMPORTANT

If this is a replacement application, follow the appliance manufacturer's instructions. The manufacturer usually provides wiring diagrams, start-up and checkout instructions and service procedures for their system. If manufacturer's instructions are not available, the information below may be used as a general guide.

S87D CONTROL MODULE

Select a location within 30 in. [762 mm] maximum of the burner that will permit a direct cable route to the Q347A spark igniter. Ready access to the terminals is necessary for wiring and servicing. Do not exceed the ambient temperature rating given in the SPECIFICATION section.

The S87 may be mounted in any position. See Fig. 1 for mounting dimensions. Use No. 6-32 machine screws or No. 8 sheetmetal screws 1 in. long for fastening. Fasten securely.

Q347A SPARK IGNITER-SENSOR

The Q347A should be rigidly mounted in an accessible location. It must remain in a fixed position relative to the main burner. The Q347 may be mounted on a separate bracket or on the same bracket with the Q354A Flame Sensor. On multiple burners, the Q347 may be mounted at one end of the row and the Q354 at the other end to delay spark cutoff until all burners are ignited.

IMPORTANT

The ignition cable limits the distance between the Q347 and S87 to 30 in. [762 mm] or less. This may affect the location selected for the Q347 and/or S87. Ignition cable must not touch grounded object or current-carrying wires.

Position the Q347 so that only the tips of the electrodes are immersed in the burner flame. The burner must ignite smoothly — usually this will be accomplished with tip of electrodes (spark gap) spaced approximately 1/4 in. [6.4 mm] from the surface of the burner. Gas must flow into one of the three open sides of the spark gap (where outer electrode does not block gas). The center electrode must not be near any ground.

The spark gap is factory-adjusted to 5/32 in. [4 mm]. If this setting is disturbed in shipment or installation, readjust by carefully bending the bent tip of the ground (outer) electrode only.

Q354A FLAME SENSOR

The Q354 should be rigidly mounted in an accessible location. It must remain in a fixed position relative to the main burner. Mount the Q354 on a separate bracket or on the same bracket with the Q347 Spark Igniter.

Tip of rod must be immersed in main burner flame. Depth of immersion (usually about 1 in. [25.4 mm]) and distance from rod to burner surface (usually 1/4 in. [6.4 mm]) depends on type of burner and flame configuration. Position selected must produce sensor current of 1.5 microamperes (minimum). See Fig. 9, Page 10, to measure current.

The main burner serves as the grounding area for the flame signal. Install ground wire from the main burner to the ground terminal of the S87D.

AUXILIARY CONTROLS

CAUTION

1. If a common transformer is used to power both the S87D and the burner valve circuit, its capacity (VA) must be adequate for all of the system components (see Table 2).
2. Turn off gas supply before beginning installation. After installing gas control, be sure to conduct Gas Leak Test, page 8.

Install the auxiliary controls required in the complete control system, following the instructions of the appliance or control manufacturer.

TABLE 2—TRANSFORMER RATINGS FOR S87D AND DUAL VALVE COMBINATION GAS CONTROL.

MINIMUM VA RATING (24 V transformer)	TOTAL VALVE CURRENT (in amperes)	S87D CURRENT (in amperes)
20	Up to 0.6	0.2
30	0.7 to 1.0	0.2
40	1.1 to 1.4	0.2
55	1.5 to 2.0	0.2

WIRING

GENERAL PRECAUTIONS

1. Check the wiring diagram furnished by the appliance manufacturer, if available, for circuits differing from the ones shown in this publication. Carefully follow all instructions affecting the general procedures outlined below.
2. All wiring must comply with applicable electrical codes and ordinances.
3. Disconnect the power supply before wiring to prevent electrical shock and equipment damage.
4. The flame sensor leadwire should be kept as short as possible and should not be allowed to rest against grounded metal surfaces.
5. A common ground is required for the S87D Electroic Module, Q347A Spark Igniter-Sensor, Q354A Flame Sensor and main burner. The S87 ground (GND) terminal internally grounds one side of the transformer. Any auxiliary controls or limits used must not be in the grounded leg.
6. Ignition cable should not touch any metal surface or current-carrying wires. It must not be more than 30 in. [762 mm] long.
7. Do not short valve terminals as this may burn out the temperature controller or the transformer.

S87D CONTROL MODULE

1. Connect the system components to the S87D quick-connect terminals as shown in the wiring diagrams. Refer to the appliance manufacturer's instructions for wiring any other auxiliary controls.

2. Adjust thermostat heat anticipator to match system current draw. The current draw equals the total current required for the S87D (0.2 A) plus the gas valve. Gas valve must be designed for DSI application.

Q347A SPARK IGNITER AND IGNITION CABLE

1. Connect the GND burner, quick-connect terminal on the S87D to one of the mounting screws on the Q347A as shown in Fig. 4. The S87 and Q347 must have a common ground. Use thermoplastic insulated wire with a minimum rating of 105 C [221 F] for the ground wire; asbestos insulation is not acceptable. If necessary, use a shield to protect the wire from radiant heat generated by the burner.

2. Connect one end of the ignition cable (supplied with the Y343B package) to the ignition terminal on the S87 and the other end to the Q347.

NOTE: Ignition cable must not run in contact with a metal surface or current-carrying wires. Use ceramic or plastic standoff insulators to protect voltage to spark electrode from being reduced. If cable passes through a metal panel, use an insulated bushing in the panel to prevent voltage reduction to spark electrode.

Q354A FLAME SENSOR

1. Male quick-connect terminals (1/4 in. [6.4 mm]) are provided on both the Q354 and S87D. Connect the SENSOR terminal on the S87 to the terminal on the Q354 as shown in Fig. 4. Use thermoplastic insulated wire with a minimum rating of 105 C [221 F] for the flame sensor leadwire; asbestos insulation is not acceptable.

AUXILIARY CONTROLS

WARNING

The auxiliary controls (transformer, thermostat, limit) must be connected to the 24 V terminal, gas valve must be connected to the VALVE terminals and the alarm control to the ALARM terminal on the S87D. Only one side of the transformer secondary can be connected to the 24 V (GND) terminal. A short to ground could cause the system to malfunction.

Connect the system transformer, thermostat, high temperature limit controller, combination gas valve and alarm (if used) as shown in Fig. 4.

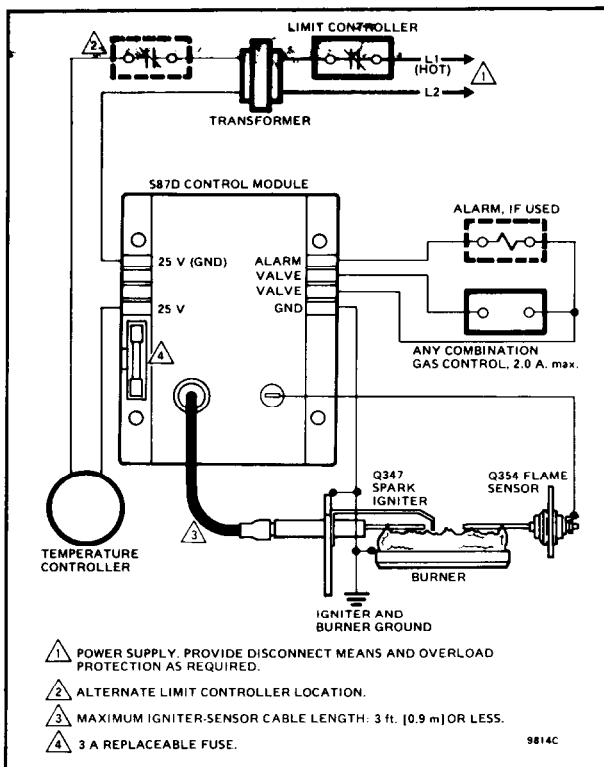

FIG. 4—WIRING HOOKUP FOR Y343B PACKAGE IN A TYPICAL DSI HEATING SYSTEM.

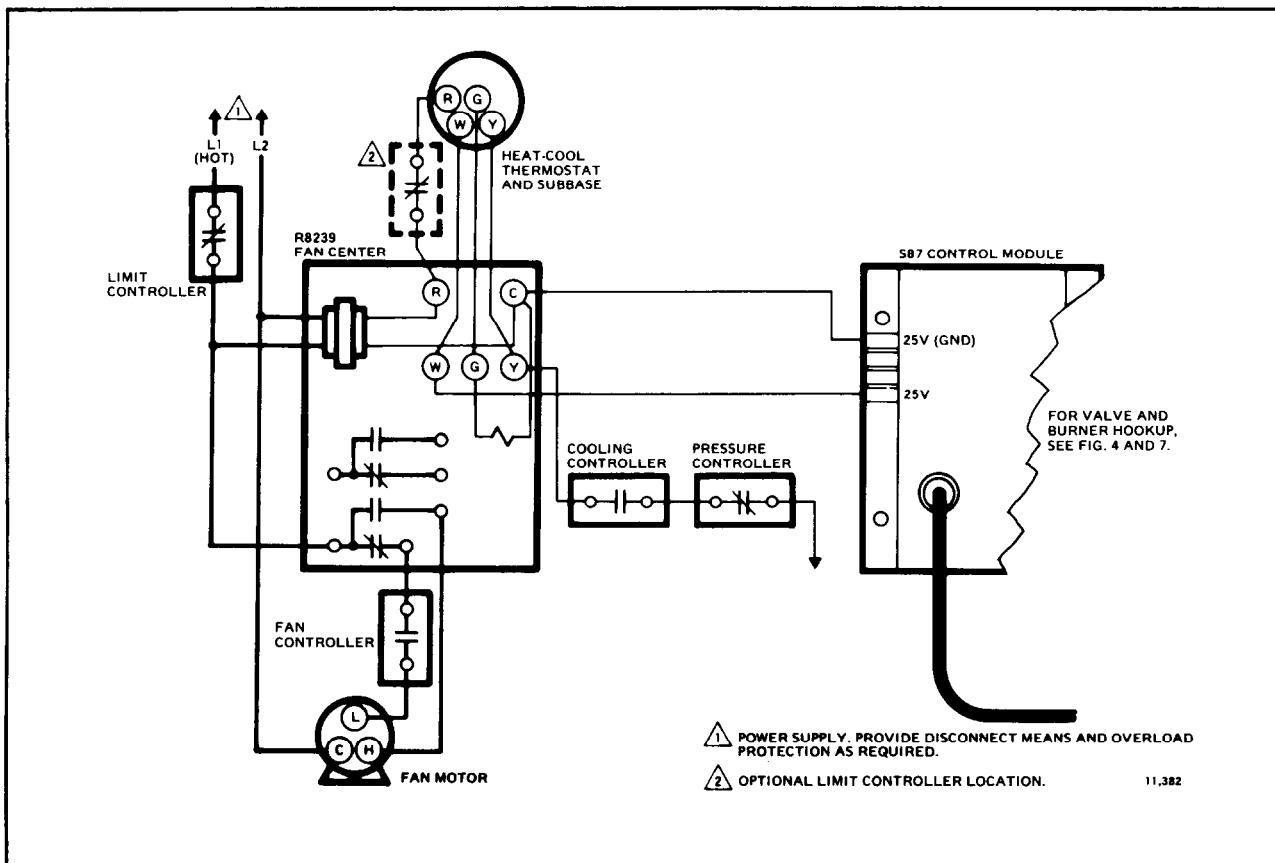

FIG. 5—WIRING HOOKUP FOR Y343B PACKAGE IN A TYPICAL HEATING-COOLING SYSTEM.

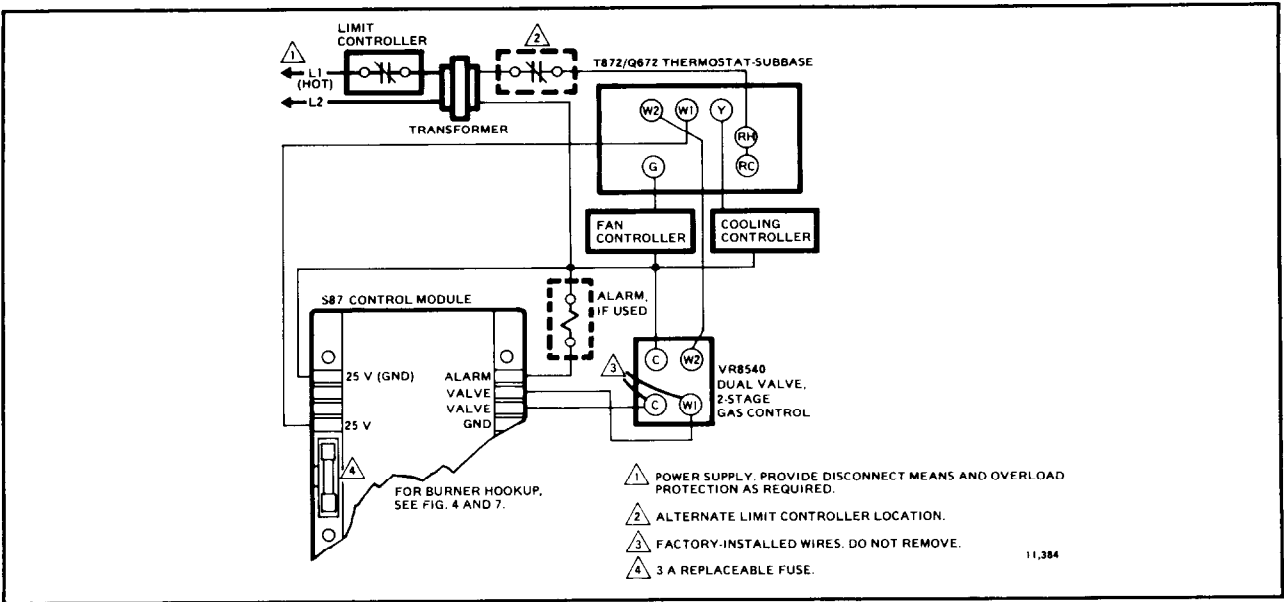

FIG. 6—WIRING HOOKUP FOR Y343B PACKAGE IN A TYPICAL TWO-STAGE DSI HEATING SYSTEM.

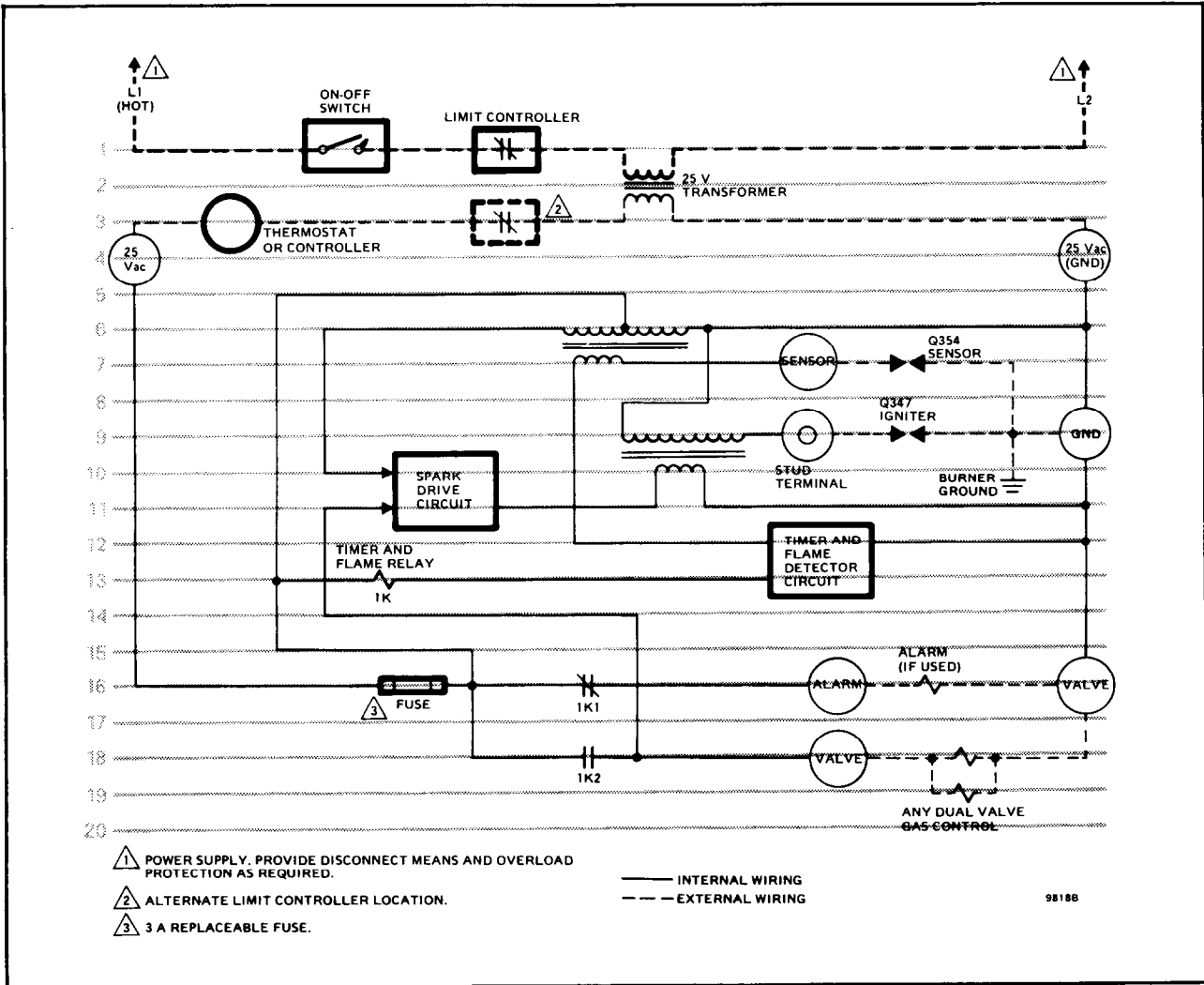

FIG. 7—S87D SIMPLIFIED SCHEMATIC DIAGRAM.

STARTUP AND CHECKOUT

The following start-up and checkout procedures are basic to the S87. If possible, refer to the specific instructions provided by the appliance manufacturer since the application and controls used may differ.

NOTE: If one of the system components fails, the S87 will either not operate or it will go into safety lockout (depending on the type of failure). If the system does not perform as outlined in START SYSTEM and CHECK SAFETY LOCKOUT steps below, refer to the SERVICE section to determine the cause.

START SYSTEM

1. Turn on power and gas supply.
2. Perform the following Test for Gas Leaks.

WARNING

DO NOT OMIT THIS TEST.

With main burner in operation, paint pipe joints, gas tubing connections, and valve gasket lines with rich soap and water solution. Bubbles indicate gas leaks. To stop leak, tighten joints and/or screws, or replace gasket. Never use a flame to check for gas leaks.

3. Set temperature controller to call for heat and watch for spark at the igniter. Time the length of the spark operation; it must be within the lockout timing period (see Table 3).

4. Check that the system starts as follows: Spark turns on, gas valve opens at once, and burner ignites after gas reaches the main burner. Once burner flame is established, spark igniter shuts off.

NOTE: If the gas control has been replaced or serviced, lightoff may not be satisfactory until air has been purged from the gas line or the gas input and combustion air have been adjusted (see manufacturer's instructions).

CHECK SAFETY LOCKOUT

1. With the system power off and the temperature controller set to call for heat, manually shut off the gas supply.
2. Turn power on to energize the S87 and begin spark ignition. Immediately start timing.
3. Determine the number of seconds to safety lockout (spark cutoff). It should not exceed the time shown in Table 3.

TABLE 3—S87 LOCKOUT TIMES.

SPECIFIED S87 LOCKOUT TIME (stamped on S87 Control Module)	SAFETY LOCKOUT TIME SHOULD NOT EXCEED—
11.0 sec.	15.0 sec.

4. After spark cutoff, manually reopen gas supply cock. No gas should flow to the main burner.
5. Reset system as described below.

RESET S87 AFTER SAFETY LOCKOUT

If the control goes into safety lockout, it will remain locked out until the system is reset.

To reset the system, adjust the thermostat setting below room temperature, wait 30 seconds, and move the thermostat setting up to call for heat. Normal ignition should occur as described in START SYSTEM, above.

CHECKOUT

Start system and observe operation through at least one complete cycle to make certain all controls are operating safely.

OPERATION

OPERATION

The S87D is powered by a 24 Vac transformer and activated when the temperature controller calls for heat. Operation is as follows (refer to Fig. 8).

When the S87 is activated, an internal transformer provides power to the electronic generator circuit for spark ignition and the safety lockout timing begins. At the same time, the S87 opens the gas control's main valves which allows gas to flow to the main burner.

Power is supplied to the generator until:

- the main burner lights and flame sensor current reaches 1.5 μ A, or...
- the safety lockout timing period ends.

If the main burner lights, a circuit is completed through the flame to the burner head to ground. This current flow returns the safety lockout timer to the reset (normal) condition and interrupts the spark ignition

circuit. Should the current flow be interrupted; i.e., flame-out condition, the trial-for-ignition begins again.

The S87 will keep the gas control main valve open as long as there is a call for heat and current through the flame sensing circuit. If, however, the safety lockout timing period ends before the main burner lights or the flame sensor establishes enough current, the system will go into safety lockout.

When the system goes into safety lockout, power to the generator is interrupted, the gas control circuit is interrupted and the alarm relay circuit is completed. The system will stay locked out until it is reset by moving the thermostat set point below room temperature, no call for heat, for 30 seconds. Then, re-energize the system by moving the thermostat set point 5 F [2.8 C] above room temperature.

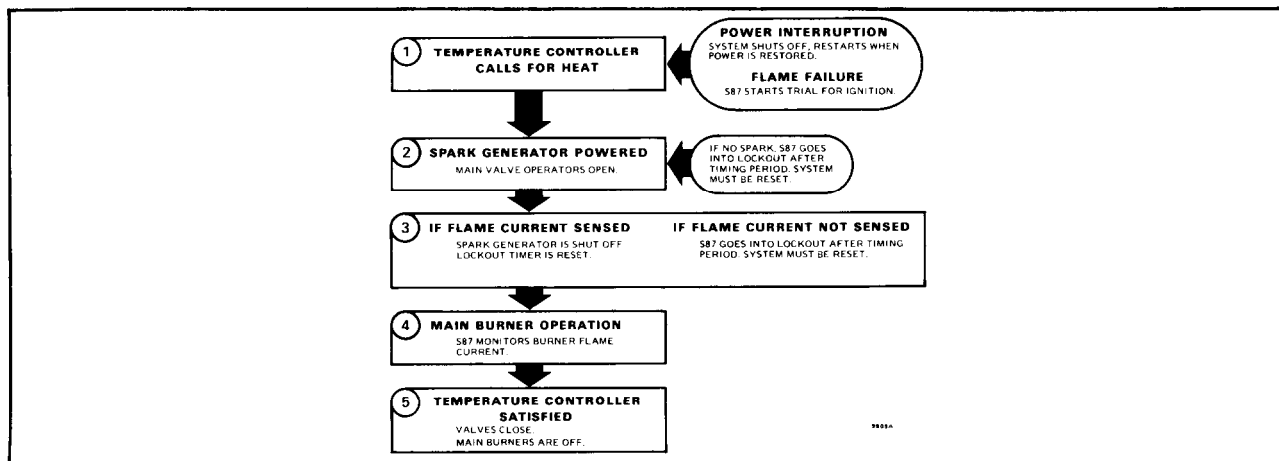

FIG. 8—NORMAL SYSTEM SEQUENCE OF OPERATION.

SERVICE

IMPORTANT

1. Only persons trained and experienced in DSI systems should service this equipment.
2. If a condition exists that causes the S87D electronic module to go into safety lockout, meter readings must be taken quickly after restart — within trial-for-ignition period.
3. Always de-energize the system for at least 30 seconds before recycling for further tests.
4. The S87D electronic module cannot be repaired. If the troubleshooting procedure indicates a malfunction in the S87, it must be replaced.
5. The following service procedures are for the S87 and basic DSI systems. On all installations, refer to the appliance manufacturer's service instructions.

PRELIMINARY CHECK

The following checks should be made before troubleshooting the system.

1. Check for power to the heating appliance and the S87D.
2. Check fuse on S87D electronic module and replace if blown.
3. Make certain that the manual shutoff gas cock in the supply line and on the combination gas control valve are open.
4. Make certain that all wiring connections are clean and tight.
5. Make certain the S87 is not in safety lockout. De-energize the system by moving the thermostat set point below room temperature. Wait at least 30 seconds and re-energize the system by moving the thermostat set point 5 F [2.8 C] above room temperature.
6. Check ceramic insulator on flame sensor and spark igniter. A cracked insulator will allow current to leak to ground. Replace device if insulator is cracked.
7. Check the flame sensor and its mounting bracket. Correct the position if bent out of shape.
8. Review the S87 normal sequence of operation. See START SYSTEM section.

S87D COMPONENT CHECKS

SPARK IGNITION CIRCUIT

The step-up transformer in the S87 provides spark ignition at 15,000 volts (open circuit). To check the spark ignition circuit, proceed as follows:

1. Shut off gas supply to the gas control.
2. Disconnect the ignition cable at the S87 stud terminal to isolate the circuit from the spark-igniter. Prepare a short jumper wire, using heavily insulated wire such as ignition cable.

CAUTION

Do not allow fingers to touch either the stripped end of the jumper or the stud terminal. This is a very high voltage circuit and electrical shock can result.

3. Perform this test immediately upon energizing the system -- before the S87D goes into safety lockout and interrupts the spark circuit. Touch one end of the jumper firmly to the S87 GND terminal. (DO NOT remove the existing ground lead.) Slowly move the other end of the jumper wire toward the stud terminal on the S87 to establish a spark. Pull the wire away from the stud and note the length of gap at which spark discontinues.

4. A spark length of 1/8 in. [3.2 mm] or more indicates satisfactory voltage output. If no arc can be established or the maximum spark is less than 1/8 in. [3.2 mm], and power to the S87 input terminals was proved, replace the S87.

IGNITION CABLE

Check the electrical continuity of the ignition cable and make certain the cable is not in contact with metal surfaces. The total cable length should not exceed 3 ft [0.9 m]. A loose connection to the spark igniter-sensor may not conduct a signal even though spark ignition is satisfactory. Check connections to the stud terminal on the S87D and the boot connection to the spark igniter-sensor and make certain they are clean and tight.

GROUNDING CONNECTIONS

A common ground is required for the burner, spark igniter-sensor mounting bracket and the GND terminal of the S87. If ground is poor or erratic, safety shutdown may occur occasionally even though operation is normal at time of checkout. Therefore, if nuisance shutdowns have been reported, be sure to check ground connections.

Electrical ground connections at the spark igniter-sensor and the S87D must be clean and tight. If leadwire is damaged or deteriorated, use only No. 14 or No. 18 gauge, moisture-resistant, thermoplastic insulated wire with 105 C [221 F] minimum rating as replacement.

FLAME SENSOR CIRCUIT

The S87D provides ac power to the flame sensor which the burner flame rectifies to direct current. If the flame signal back to the S87 is not at least 1.5 μ A dc, the system will lock out.

The output of the flame sensing circuit can be checked directly on the S87D. Check the flame sensing circuit as follows.

1. Connect a meter (dc microammeter scale) in series with the sensor wire as shown in Fig. 9. Use the Honeywell W136A Test Meter or equivalent. Disconnect the sensor wire at the S87D. Connect the red (positive) lead of the meter to the free end of the sensor wire. Connect the black (negative) meter lead to the sensor terminal on the S87.

2. Restart the system and read the meter. The flame sensor current must be at least 1.5 μ A and steady. If the reading is less than 1.5 μ A or unsteady, see **LOW OR UNSTEADY FLAME CURRENT** section, below.

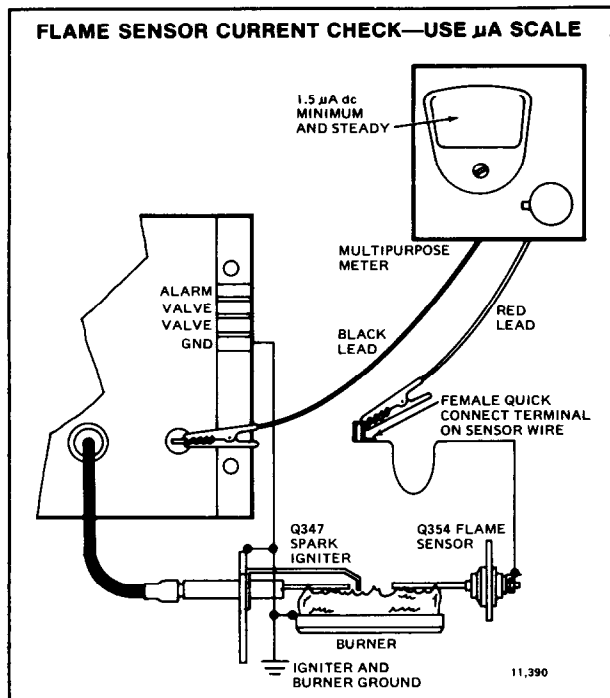

FIG. 9—S87 FLAME CURRENT MEASUREMENT.

LOW OR UNSTEADY FLAME CURRENT

If the current to the S87D flame circuit is less than 1.5 μ A or is unsteady, check the burner flame and flame sensor location and electrical connections as follows.

Burner Flame

The flame sensor must be constantly immersed in flame. Check burner flame conditions as shown in Fig. 10. If necessary, improve the flame condition or relocate the flame sensor to a place on the main burner where flame conditions are better.

Flame Sensor

The flame signal is best when about 1 in. [25.4 mm] of flame rod is immersed in the burner flame. A bent flame rod or mounting bracket can affect flame signal. Bend flame rod bracket to correct position if necessary. Excess temperature at the ceramic flame rod insulator may cause leakage to ground, decreasing the flame signal. Replace the flame sensor if the ceramic insulator is cracked, and relocate the sensor to an area of lower ambient temperature if necessary.

Electrical Connections and Shorts

Connections at the flame sensor must be clean and tight. If wiring needs replacement, use moisture-resistant No. 18 wire rated for continuous duty up to 105 C [221 F].

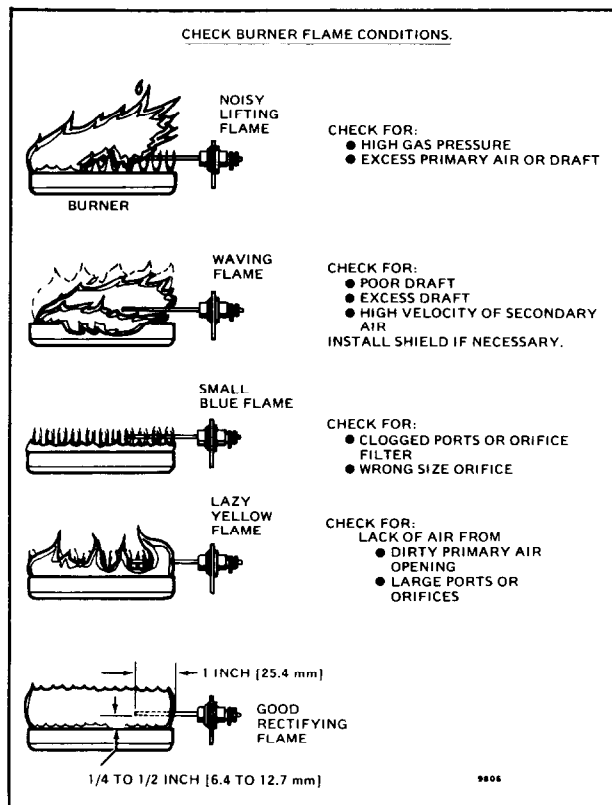

FIG. 10—BURNER FLAME CONDITIONS.

CHECKOUT AFTER SERVICE

Perform the following steps before leaving the job (described in CHECKOUT section)—

- START SYSTEM
- SAFETY LOCKOUT CHECK
- SAFETY LOCKOUT RESET

Also perform any other checks recommended by the heating appliance manufacturer if system components other than the Y343B were serviced.

TROUBLESHOOTING

Start the system by setting the thermostat (temperature controller) to call for heat. Observe the system response and establish the type of malfunction or deviation from normal operation by using Table 4.

Use Table 4 by following the instructions in the boxes. If the condition is true or okay (answer is yes), go

down to the next box. If the condition is not true or not okay (answer is no), go to the box at right. Continue checking and answering conditions in each box until a problem and/or repair is explained. After any maintenance or repair, the troubleshooting sequence should be repeated until normal system operation is obtained.

TABLE 4—S87 DIRECT SPARK IGNITION SYSTEM TROUBLESHOOTING

